

Compact First Stage Regulators

LV3403TR

Application

Ideal for use as a first stage regulator on any domestic size ASME or DOT container in propane gas installations requiring up to 1,500,000 BTU's per hour. The regulator is factory set to reduce container pressure to an intermediate pressure of approximately 10 psig (0.69 barg).

Features

- Compact design can be connected to a service valve using either a POL adapter or a RegO product pigtail.
- Large threaded 3/8" F.NPT bonnet vent can easily be piped-away underground installations without the need of glue kits or extra adapters.
- Non Adjustable
- Large flow orifice resists freeze ups due to water concentration in LPG vapor.
- Design provides for good flow regulation at both high and low container pressures.
- Built in relief valve and travel stop comply with NFPA 58 over pressure requirements.
- Incorporates 1/8" F.NPT downstream pressure tap for an easy inline check of the regulator's delivery pressure.
- Molded diaphragm provides an o-ring type seal between the body and bonnet.
- Body and bonnet are assembled in the USA using the unique, patented RegUlok seal system.
- Fully painted in brilliant red for complete corrosion protection.
- Mounting bracket available as an accessory: part number 2302-31.



LV3403TR

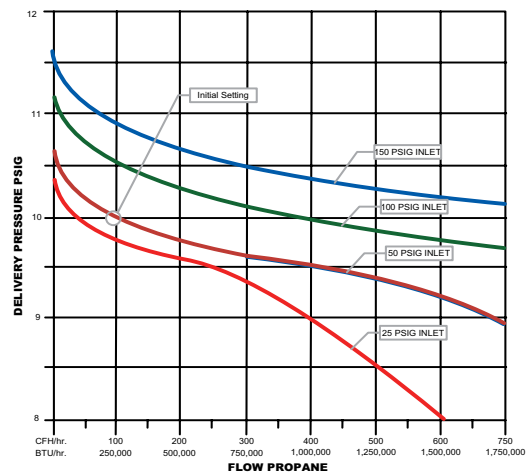
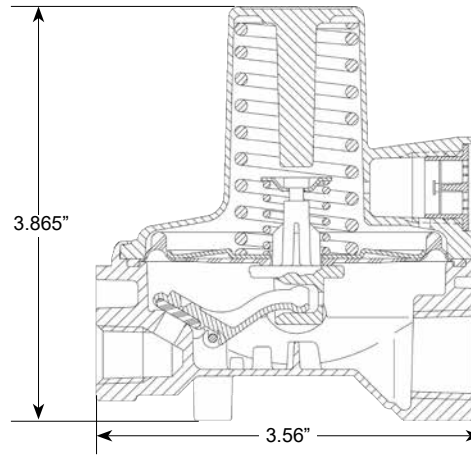

Materials

Body Zinc
 Bonnet Zinc
 Spring Steel
 Seat Disc Resilient Rubber
 Diaphragm Integrated Fabric and Synthetic Rubber



Ordering Information

Part Number	Inlet Connection	Outlet Connection	Orifice Size	Factory Delivery Pressure (psig)	Factory Delivery Pressure (barg)	Bonnet Vent Position	Vapor Capacity BTU/hr Propane*
LV3403TR	1/4" F.NPT	1/2" F.NPT	7/32"	10 psig	0.69 barg	Over Outlet	1,500,000
LV3403TRV9						9:00	

* Maximum flow based on inlet pressure 20 PSIG higher than the regulator setting and delivery pressure 20% lower than the regulator setting and delivery pressure 20% lower than the setting.